

Doosan Infracore

Driving innovation for global competitiveness with
IBM and Dassault Systèmes PLM solutions



Doosan Infracore Objectives:

- Optimize design infrastructure to achieve US\$10.7 billion revenue goal
- Streamline internal processes
- Reduce product design time and production costs
- Enable global collaboration with its expanding value chain

Company Overview

Founded in 1937 as Chosun Machine Works, Doosan Infracore has become a leader in Korea's machinery industry developing new technologies and improving product quality. Its products include construction equipment, industrial vehicles, diesel engines, power supply equipment, machine tools, factory automation equipment, and defense products.

With 29,800 employees in 33 countries, and annual turnover (2006) of US\$3.53 billion, Doosan Infracore ranks among the top five construction equipment manufacturers in the world due to the competitiveness of its products and the company's continuous drive for innovation.

To secure its leadership position as a global industrial machinery manufacturer, Doosan Infracore has been expanding relations with overseas investment firms and advanced technology companies to leverage cooperative work and assets, including technical collaborations and business partnerships.

Business Challenges

With a focus on innovation and product quality, Doosan Infracore strives to meet the growing global demand for high performance machinery. In addition, the company aims to improve its fifth-place ranking in global Infrastructure Support Business (ISB). Doosan Infracore has translated this objective into the slogan 'Vision 10-10' referring to its goal to achieve KRW ten trillion Won (US\$10.7 billion) in annual revenue and an operating profit margin of ten % by 2010.

To achieve these goals and stay ahead of the competition, Doosan Infracore aims to reduce the time and cost of developing new and innovative products. In addition, the company hopes to be more flexible when responding to customer requirements while simultaneously enhancing its service offering.



Solution

Doosan Infracore selected IBM and Dassault Systèmes (DS) Product Lifecycle Management (PLM) solutions including CATIA and ENOVIA VPLM to enable it to collaborate globally, streamline internal processes, and expand its value chain with Real-Time Enterprise (RTE) applications.

CATIA for collaborative PLM

Doosan Infracore had a 2D-based CAD solution as well as a product data management (PDM) system since 1995 but managed released data from engineering and manufacturing separately. The company knew it needed to implement corporate-wide initiatives to simplify its increasingly complex IT environment. Most importantly, it needed to evolve from 2D to virtual 3D CAD, fully integrated with PLM solutions, so that all Doosan Infracore contributors could use the same product data to perform concurrent design work, make informed decisions, and collaborate in real time.

Doosan Infracore adopted CATIA V5 and standardized all its design processes based on 3D. At the same time, a data management system based on ENOVIA VPLM was implemented by IBM PLM & IBM GBS to establish efficient 3D management of work-in-process data and collaboration processes, leveraging the entire range of CATIA design capabilities.

ENOVIA VPLM for concurrent engineering

“A key enabler of our business transformation is the ability to manage 3D design data using an integrated system that allows engineers to iterate on their designs and to collaborate more efficiently in a secure environment,” says Seong-Jin Hong, Senior Researcher, Doosan Infracore. “As a result, design in context and concurrent engineering became possible. At the same time, we have been able to implement configured DMU, which is a unique function of ENOVIA VPLM, thereby accelerating design analysis and reviews, resulting in maximum product design efficiency.”



*Tae-hwan Kim
PLM Project Manager Construction Machinery Business Group
Doosan Infracore*

“We needed to promote end-to-end product and process innovation by improving our product development strategy. This could only be achieved through efficient management of the entire product lifecycle – from design all the way to production and maintenance.”



*Hak-Seong Uhm, Principal Researcher
Construction Equipment Business Group
Doosan Infracore*

“Thanks to CATIA for 3D product design and ENOVIA VPLM for concurrent engineering and work-in-process data management, we are already seeing amazing results throughout our collaborative design process.”

Results

Improved design productivity and performance

Doosan Infracore has deployed the CATIA Multi-Body Design Methodology and other best practices to increase quality and innovation, and as a result, has achieved a more than 50 % improvement in design quality as well as an increase in BOM management efficiency. “Designers who were used to the existing 2D technology were initially reticent about adapting the CATIA 3D system,” explains Tae-Hwan Kim, a principal researcher of Doosan Infracore who led the PLM implementation. “However, as CATIA built-in knowledge templates accumulated over time, data reuse became a critical enabler and design productivity improved by 30 %. Now that the 3D design methodologies have been implemented, when we jokingly ask the designers if they wish to return to the old 2D technology, they all shake their heads and say ‘no!’”

Concurrent development reduces time and improves quality

Doosan Infracore has implemented an integrated design environment that allows concurrent engineering and collaborative work thanks to ENOVIA VPLM. Users can conveniently store and retrieve design data in real time as the product evolves. This enables both design teams and post-processing departments to gain early insight into each design project from the initial design stage, reducing errors and rework and obtaining a higher quality product much earlier in the process.

A PLM system powered by workflow management

With the successful implementation of CATIA and ENOVIA VPLM, Doosan Infracore has laid the foundation for an integrated PLM development strategy that is helping it to achieve its business goals. In addition to lifecycle design and manufacturing process support, Doosan Infracore is deploying ENOVIA business process solutions for both configuration management and workflow management to streamline program and project management activities.

Annual savings of US\$2.4 million in design change costs

Due to its newly integrated design platform, Doosan Infracore expects to reduce the number of design changes resulting in cost savings of KRW2.3 billion (US\$2.4 million).

Worldwide recognition as a leader in innovation

Doosan Infracore has successfully established the foundation for "a world-class 3D PLM practice" by making a rapid transition from 2D to 3D design and implementing a 3D collaborative work environment. The company has successfully migrated all of its legacy data and integrated its design and production processes in order to achieve maximum improvements. Doosan Infracore is proud of the unique collaborative design work infrastructure it has built, confident that it has laid the foundation for reaching its PLM vision long before the competition. Thanks to its strategic partnership with IBM and Dassault Systèmes, Doosan Infracore is now in a favorable position to lead the implementation of 3D PLM standards for the global heavy equipment industry.

PLM key benefits:

30%

cut in new product development time

Design reuse means optimized new product development

US\$2.4 million

in annual savings

Substantial cost savings thanks to fewer engineering changes

50%

increase in design quality

CATIA Multi-Body Design Methodology doubles design quality

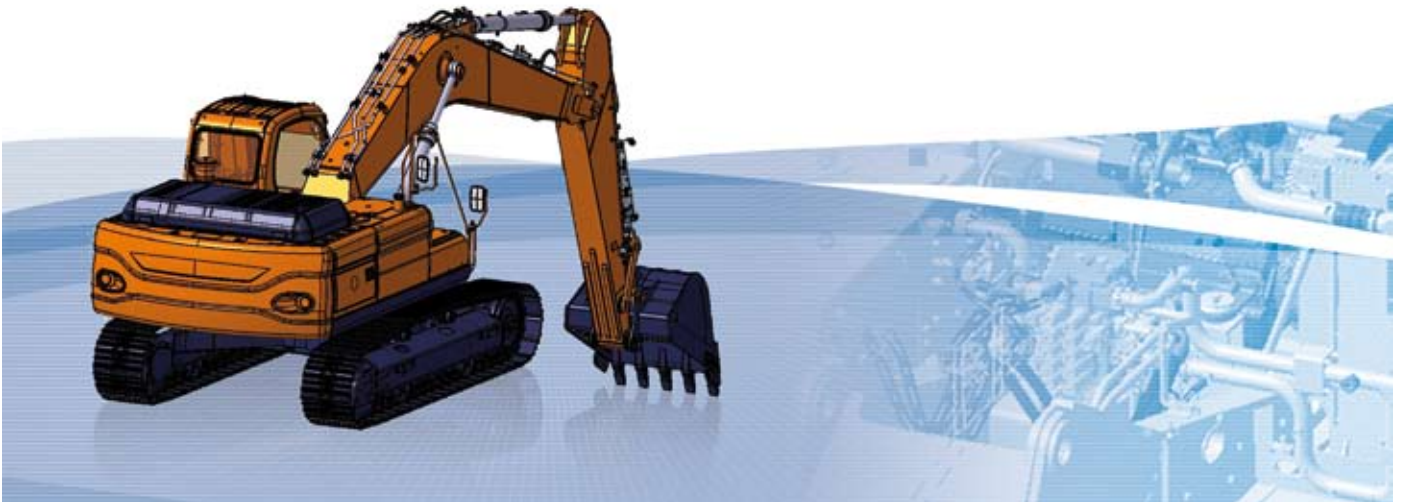

Tae-hwan Kim
PLM Project Manager Construction Machinery Business Group
Doosan Infracore

“CATIA and ENOVIA VPLM are the cornerstones of Doosan Infracore’s innovation strategy, facilitating quick design and seamless collaboration in 3D.”

PLM leader within Doosan group

Doosan Infracore has gained significant expertise in engineering process consulting thanks to its 3D PLM implementation experience with CATIA and ENOVIA VPLM. It has been propagating this technical know-how to other business groups within the company, as well as to other subsidiaries of the Doosan Group through its Doosan PLM Forum, a group of users that has established itself as the company’s 3D PLM think tank.

Doosan Infracore has begun the implementation of a world-class 3D PLM strategy, which is recognized as an industry best practice, thanks to the strong leadership of its management team and the innovative fervor of its frontline users. As a result, the company has achieved dramatic improvements in design, collaboration, and overall process efficiencies, ensuring it will stay ahead of its competitors for years to come. The success of Doosan Infracore’s PLM implementation strategy is a benchmark for other business groups within the Doosan Group, thereby playing a critical role in improving the competitiveness of the entire Korean manufacturing industry.

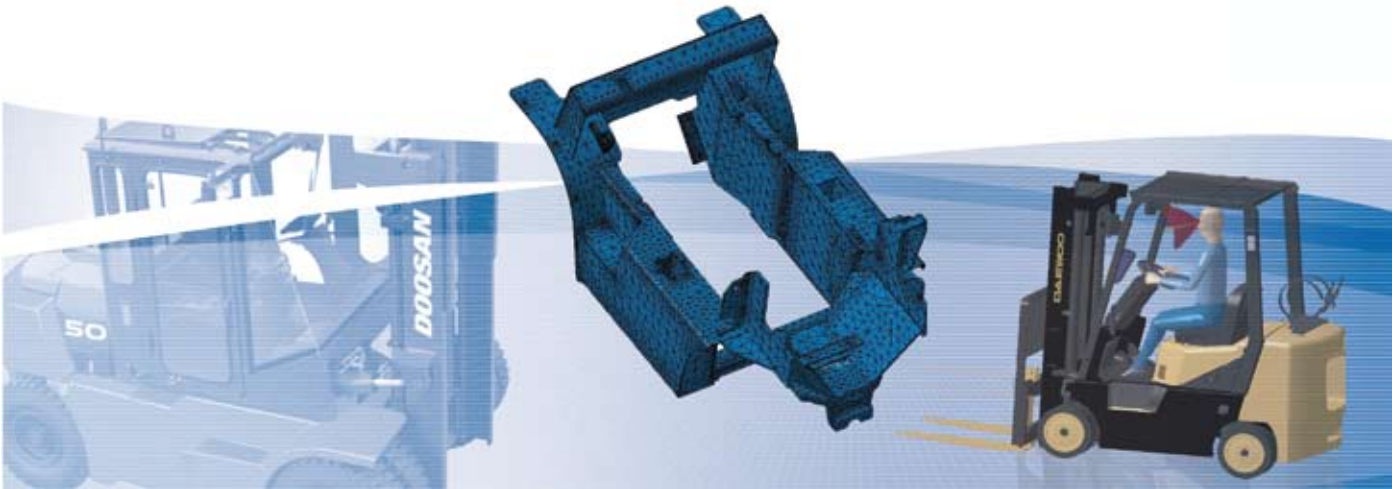

FUTURE

Thanks to the success of its PLM implementation, Doosan Infracore is now rolling out the solution to the entire group while incorporating more advanced features, such as 3D design and analysis templates and service-level management capabilities. Also, Doosan Infracore started an Information Strategy Planning (ISP) project for PDM integration & establishment PDM strategy in the entire Doosan Infracore Business Group with IBM PLM & IBM GBS and the 3D PLM strategy will also be implemented at the company's overseas branches to achieve a unified global PLM environment. Finally, through the introduction of DELMIA digital manufacturing systems such as process simulation and resource planning, and linking PLM with ERP systems, Doosan Infracore expects to realize its full PLM vision by 2009.



*Bong-Shik Kim
Production Technology Team, Construction Equipment Business Group
Doosan Infracore*

“We have achieved significant enterprise process improvements, including simplified product design and task management and data retrieval, automatic design and manufacturing change request updates, and enhanced job training preparation, all through a single 3D-based PLM system.”

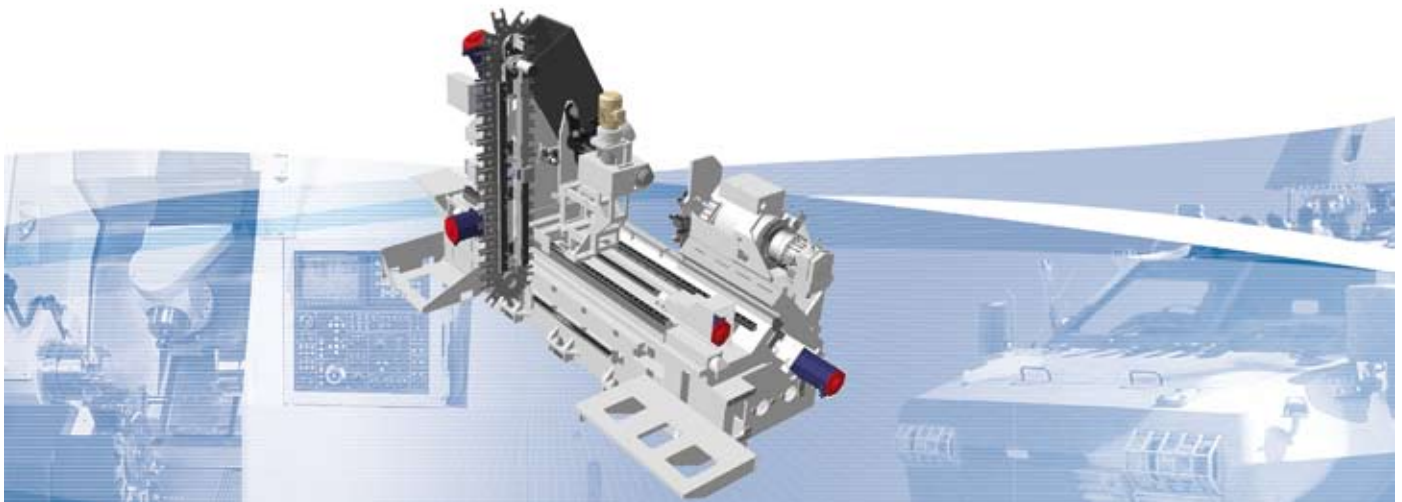

IBM and the IBM logo are registered trademarks of International Business Machines in the United States, other countries or both.

For more information, visit

www.ibm.com/solutions/plm

CATIA, ENOVIA and 3DS logo are registered trademarks of Dassault Systèmes or its subsidiaries in the US and/or other countries.

For more information, visit

www.3ds.com

